

The NG06 directional control valve series D1VW provides high functional limits up to 80 l/min in combination with a very low, energy-saving pressure drop.

A wide variety of spool options allows to design an unlimited number of hydraulic circuits.

Versions with 8 watt coils, position control, ATEX approval, surface protection and connector variants are shown in the following chapters.

The valve is also available as sandwich type, see series Z1DW in chapter 7.

Valves with explosion proof solenoids Ex e mb II see series D1VW Explosion Proof in chapter 2 and catalogue MSG11-3343/UK.

Download of the PDF file at www.parker.com/ISDE, see "Support".

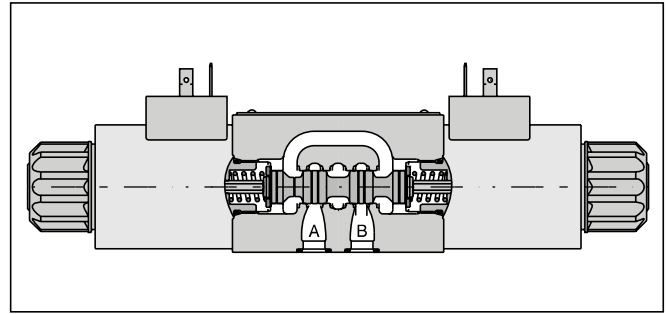
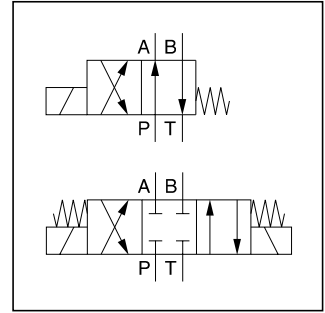
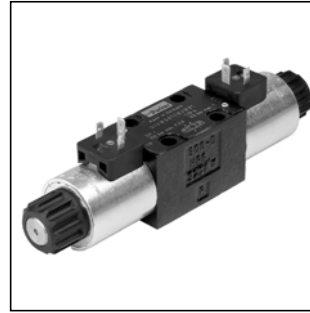

Technical data

General							
Design	Directional spool valve						
Actuation	Solenoid						
Nominal size	DIN NG06 / CETOP 03 / NFPA D03						
Mounting interface	DIN 24340 A6 / ISO 4401 / CETOP RP 121-H / NFPA D03						
Mounting position	unrestricted, preferably horizontal						
Ambient temperature	[°C] -25...+60						
MTTF _D value	[years] 150						
Weight	[kg] 1.5 (1 solenoid), 2.1 (2 solenoids)						
Vibration resistance	[g] 10 Sinus 5...2000 Hz acc. IEC 68-2-6 30 Random noise 20...2000 Hz acc. IEC 68-2-36 15 Shock acc. IEC 68-2-27						
Hydraulic							
Max. operating pressure	[bar] P, A, B: 350; T: 210 (DC), T: 140 (AC)						
Fluid	Hydraulic oil according to DIN 51524						
Fluid temperature	[°C] -20 ... +70 (NBR: -25...+70)						
Viscosity permitted	[cSt] / [mm ² /s] 2.8...400						
Viscosity recommended	[cSt] / [mm ² /s] 30...80						
Filtration	ISO 4406 (1999); 18/16/13						
Flow max.	[l/min] 80 (see shift limits)						
Leakage at 50 bar	[ml/min] Up to 10 per flow path, depending on spool, up to 15 per flow path for spool type 008 + 009						
Static / Dynamic							
Step response	see table response time						
Electrical characteristics							
Duty ratio	[%] 100 ED; CAUTION: coil temperature up to 150 °C possible						
Max. switching frequency	[1/h] 15000 (not for soft shift)						
Protection class	IP65 in accordance with EN 60529 (with correctly mounted plug-in connector)						
	Code	K	J	U	G	Y	T
Supply voltage	[V]	12 V =	24 V =	98 V =	205 V =	110 V at 50 Hz/ 120 V at 60 Hz	230 V at 50 Hz/ 240 V at 60 Hz
Tolerance supply voltage	[%]	±10	±10	±10	±10	±5	±5
Current consumption	hold [A]	2.72	1.29	0.33	0.13	0.6 / 0.55	0.3 / 0.27
Current consumption	in rush [A]	2.72	1.29	0.33	0.13	2.5 / 2.4	1.25 / 1.2
Power consumption	hold [W]	32.7 W	31 W	31.9 W	28.2 W	70 / 70 VA	70 / 70 VA
Power consumption	in rush [W]	32.7 W	31 W	31.9 W	28.2 W	280 / 290 VA	280 / 290 VA
Solenoid connection		Connector as per EN 175301-803, solenoid identification as per ISO 9461 (code W).					
Wiring min.	[mm ²]	3 x 1.5 recommended					
Wiring length max.	[m]	50 recommended					

With electrical connections the protective conductor (PE \perp) must be connected according to the relevant regulations.

2



D
 Directional control valve



1
 Size
 DIN NG06
 CETOP 03
 NFPA D03



V
 3-chamber valve



W
 Wet pin armature solenoid, threaded in tube



Spool type



Spool position

3 position spools	
Code	Spool type
	a 0 b
001	
002	
003	
004	
005	
006	
007	
008 ¹⁾	
009 ¹⁾	
010	
011	
014	
015	
016	
021	
022	
031	
032	
034	
035	
061	
081	
082	
102	
204 ¹⁾	
205 ¹⁾	

2 position spools	
Code	Spool type
	a b
020	
026	
030	
083 ¹⁾	
101	
208	

3 position spools			
Code	Spool position		
C			3 positions. Spring offset in position "0". Operated in position "a" or "b".
	Standard	Spool type 008,009, 204, 205	
E			2 positions. Spring offset in position "0".
	Operated in position "a".	Operated in position "b".	
F			2 positions. Operated in position "0".
	Spring offset in position "b".	Spring offset in position "a".	
K			2 positions. Spring offset in position "0".
	Operated in position "b".	Operated in position "a".	
M			2 positions. Operated in position "0".
	Spring offset in position "a".	Spring offset in position "b".	

2 position spools			
Code	Spool position		
	Standard	Spool type 083	
B			2 positions. Spring offset in position "b". Operated in position "a".
D			2 positions. Operated in position "a" or "b". No center or offset position.
H			2 positions. Spring offset in position "a". Operated in position "b".

¹⁾ Consider specific spool position.

²⁾ To be used in combination with rectifier plugs at 120 VAC / 230 VAC power supply.

³⁾ DC only



Ordering Code



Seals



Solenoid voltage



Solenoid connector as per EN 175301-803, **without plug** (other connectors are available for D1MW Series)



Solenoid option



Design series (not required for ordering)

Code	Solenoid option
omit	manual override (standard)
T	without manual override
S2 ³⁾	Soft shift orifice size 0.5 mm.
S3 ³⁾	Soft shift orifice size 0.75 mm.
4N ³⁾	with lockable manual override

Code	Voltage
K	12 V =
J	24 V =
U ²⁾	98 V =
G ²⁾	205 V =
Y	110 V 50 Hz / 120 V 60 Hz
T	230 V 50 Hz / 240 V 60 Hz

Code	Seals
N	NBR
V	FPM

2

Bold letters =
Short-term availability

Further spool types, solenoid voltages and connectors on request.

Flow curve

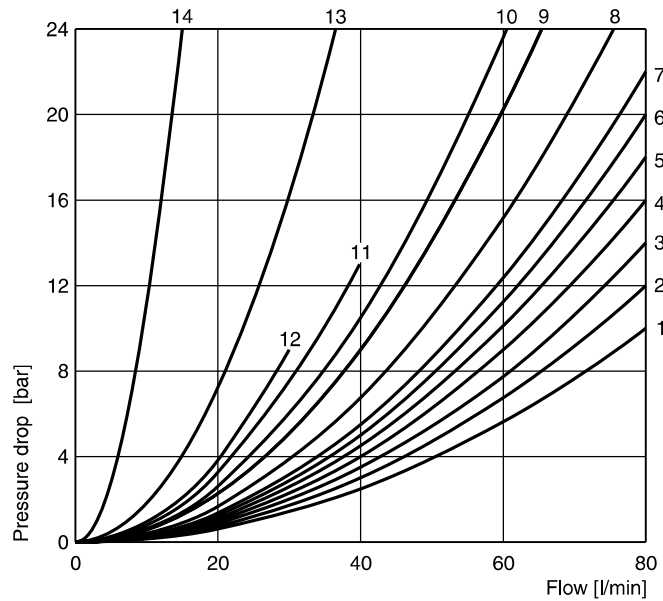

All characteristic curves measured with HLP46 at 50 °C.

Spool	Position "b"			Position "a"			Position "0"				
	P-A	B-T	P-B	P-B	A-T	P-A	P-A	P-B	A-T	B-T	P-T
001	2	2		2	2						
002	1	4		1	4		1	1	5	5	2
003	3	4		3	6				7		
004	2	3		2	3				7	7	
005	2	2		2	2		12				
006	1	4		1	4		7	7			
007	3	2		2	2			3		2	7
010	3			3							
011	2	2		2	2				14	14	
014	3	2		2	2		3		2		7
015	3	6		3	4					7	
016	2	2		2	2			12			
020B	4	4		2	3						
026B	4			4							
030B	2	3		1	2						
034	4		8	3	3				5	7	
035	3	3		4		8			7	5	
081	13	13		13	13						
082	13	13		13	13				1)	1)	
101B	11	10		10	9						
102	1	4		1	4		5	5	8	8	6
61	1	3		1	3		3	2			
83H	5	2		5	2						
208	3			2							
	P-B	A-T		P-A	B-T		P-A	P-B	A-T	B-T	P-T
008	4	5		4	5						9
009	5	5		6	7						7
83B	5	2		5	2						
204	1	3		4	3		7		4		7
205	4	3		1	3			7		4	5

Spool	Position "b"			Position "a"		
	P-A	P-B	A-B	P-B	A-T	
021	2	4		4	2	
	P-A	B-T		P-A	P-B	A-B
022	6	2		5	2	

1) Only for pressure compensation, no high flow possible.

The diagram below specifies the shift limits for valves with DC & AC solenoids. Valves with spool position “F” or “M” can only be operated up to 70 % of the limits. The specifications apply to a viscosity of 40 mm²/s and

balanced flow conditions. The shift limits can be considerably lower at unbalanced flow conditions. To avoid flow rates beyond the shift limits, a plug-in orifice can be inserted in the P-port.

Valve with standard DC solenoid

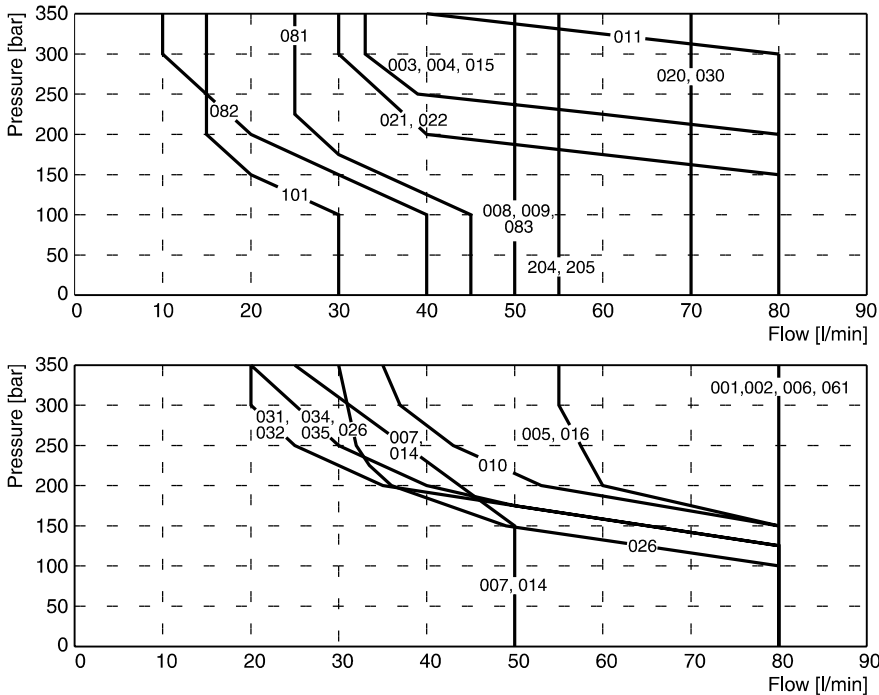

Measured with HLP46 at 50 °C, 90 % U_{nom} and warm solenoids

Valve with standard AC solenoid

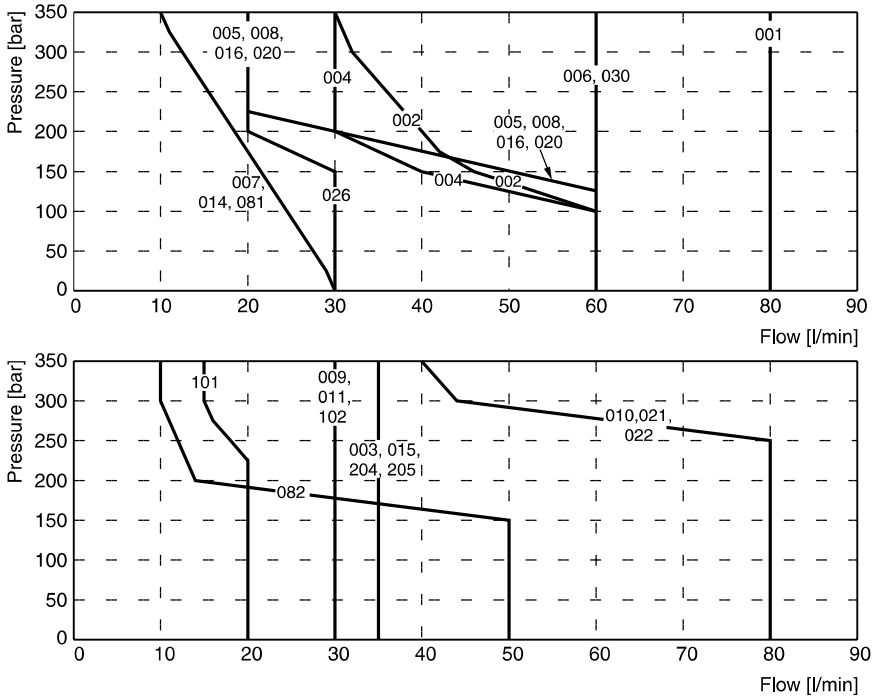

Measured with HLP46 at 50 °C, 95 % U_{nom} and warm solenoids

Shift Limits / Response Times

Shift limit diagram - Soft shift with 1 DC solenoid

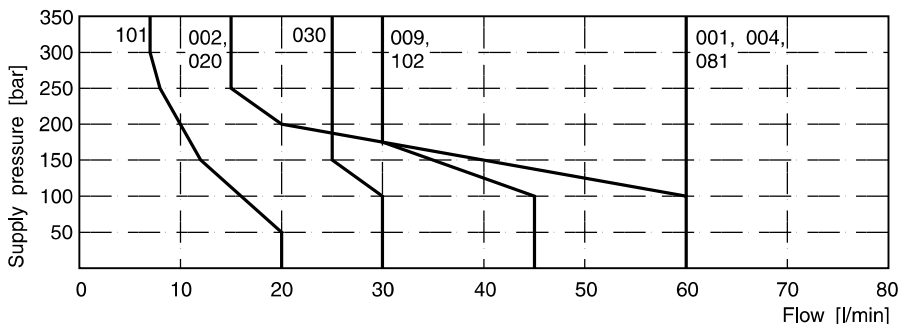

Shift limit diagram - Soft shift with 2 DC solenoids

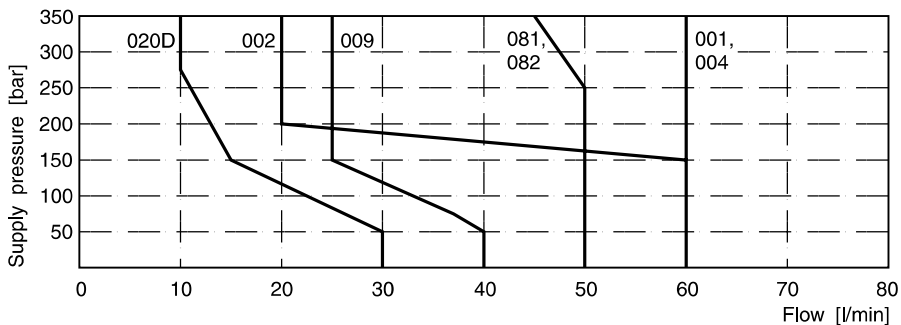

Measured with HLP46 at 50 °C, 90 % U_{nom} and warm solenoids.

Response times D1VW Standard and Soft Shift [ms]

Standard solenoid		Orifice		Energize		De-energize	
Standard DC		w/o		45 - 60		20 - 30	
Standard AC		w/o		13		20	
Standard DC with rectifier plug		w/o		60 - 70		70 - 90	

Response times soft shift		2 solenoid valve		2 solenoid valve		1 solenoid valve	
		3 positions		3 positions		2 positions	
Code	Orifice size	Center position: Closed		Center position: Open		Energize	De-energize
		Energize	De-energize	Energize	De-energize		
S2	0.50 mm	200 - 750	310 - 650	220 - 400	350 - 750	90 - 350	160 - 500
S3	0.75 mm	180 - 300	300 - 400	200 - 350	300 - 500	90 - 350	130 - 350

The lower value applies to small flow rates and low pressure, the upper value to high flow rates and high pressure.

Step response times were obtained under the following conditions: HLP46 at 50 °C with the valve operating at nominal pressure and flow. Published response times are nominal and may vary with spool, flow, pressure and temperature.

Acceleration for orifice size 0.75, code "S3" (measured against a standard valve)

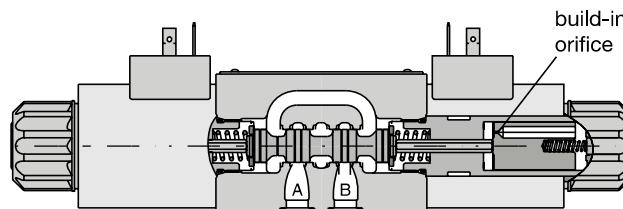
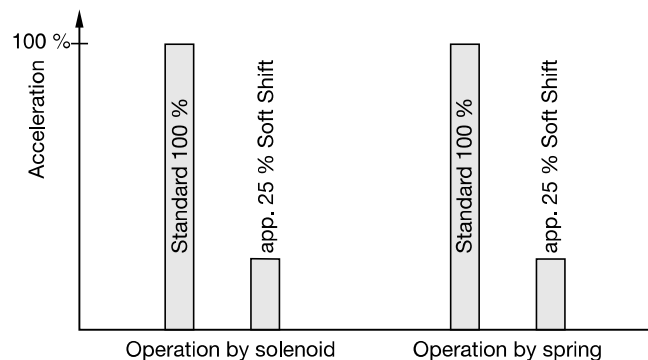

For even softer shifting, the proportional spools 081, 082, 101 and 102 can be used.

Dimensions

**Directional Control Valve
Series D1VW**

**Interface EN 175301-803, DC solenoid
B, E, F -style**

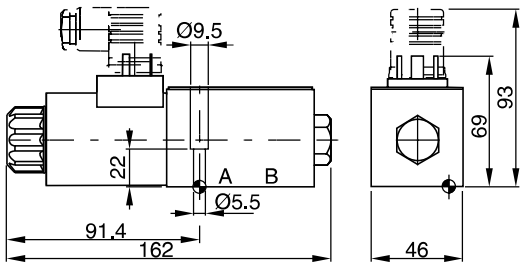

H, K, M -style

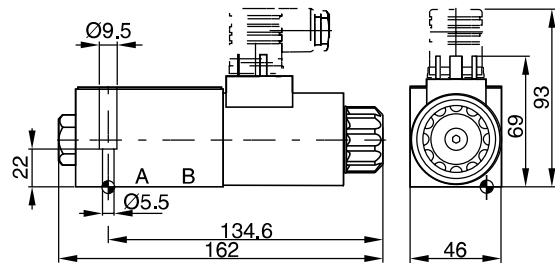

C, D -style

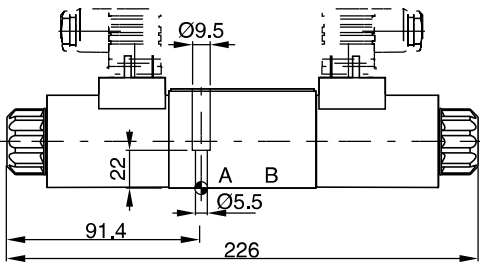

**Option 4N, with lockable manual override
(available for all styles, DC only)**

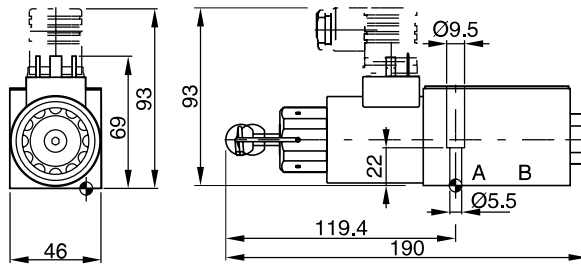

**Interface EN 175301-803, AC solenoid
B, E, F -style**

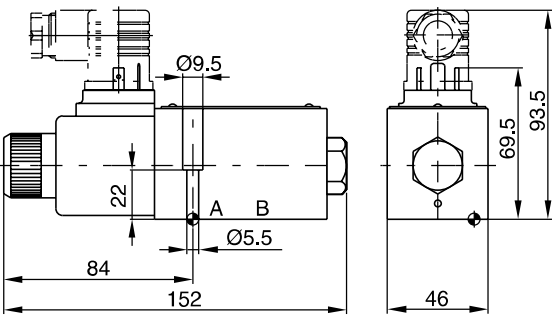



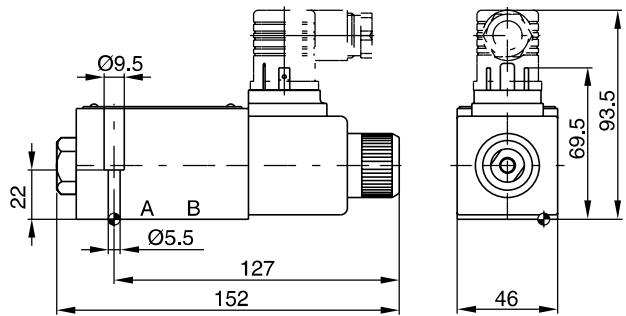

H, K, M -style

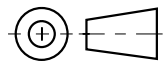
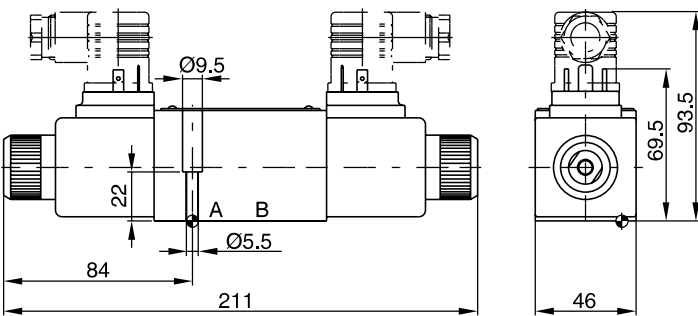

C, D -style

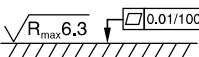

Surface finish	 Kit	 Kit	 Kit	 Kit
$\sqrt{R_{max} 6.3}$ 	BK375	4x M5x30 ISO 4762-12.9	7.6 Nm ±15 %	NBR: SK-D1VW-N-91 FPM: SK-D1VW-V-91

The space necessary to remove the plug per EN 175301-803, design type AF is at least 15 mm.
The torque for the screw M3 of the plug has to be 0.5 to 0.6 Nm.