

Characteristics

**Pilot Operated Pressure Relief Valves
Series R4V / R6V**

Pilot operated pressure relief valves series R4V (DIN 24340 Form D) and R6V (DIN 24340 Form E) consist of a manually adjusted pilot stage and a seated type main stage.

A vent function with a solenoid operated directional valve is available for circulation at minimum pressure.

Features

- Pilot operated with manual adjustment
- 2 interfaces
 - R4V subplate ISO 6264 (DIN 24340 Form D) with VV01 vent valve
 - R6V subplate ISO 6264 (DIN 24340 Form E) with CETOP 03 vent valve
- 3 pressure stages
- 3 adjustment modes:
 - hand knob
 - acorn nut with lead seal
 - cylinder lock
- Remote control via port X

Function:

Series R4V/R6V

System pressure in port P is applied via the X gallery to the spring loaded cone in the pilot head. The pilot head controls the pressure in the Z area on top of the main cartridge which is additionally kept close by the main spring. If the pilot pressure exceeds the setting pressure the pilot cone opens and thus limits the pilot pressure.

When the system pressure exceeds the pilot pressure plus the spring force, the main cartridge opens to port T and limits the pressure in port P to the adjusted level.

Series R4V/R6V with vent function

Additionally to the relief function, a solenoid operated vent valve connects the Z area to tank. This allows oil circulation from P to T at minimum pressure drop. The vent valve can either be a standard CETOP 03 valve (R6V) or a sandwich unit (R4V). For both types the vent position can be either at the energized or de-energized solenoid.



R6V06



R6V06 with vent valve



R4V06 with vent valve

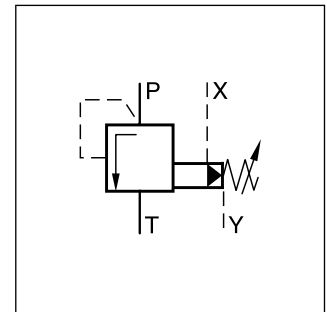

4

R6V06 with vent valve

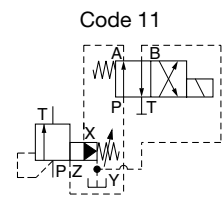
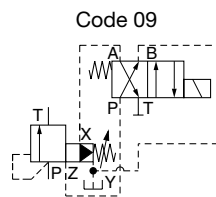
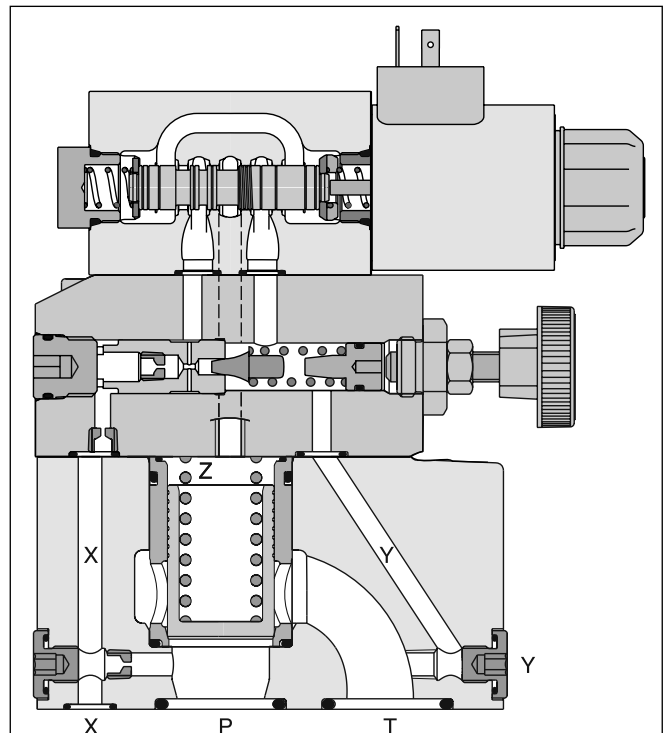

Ordering Code

4

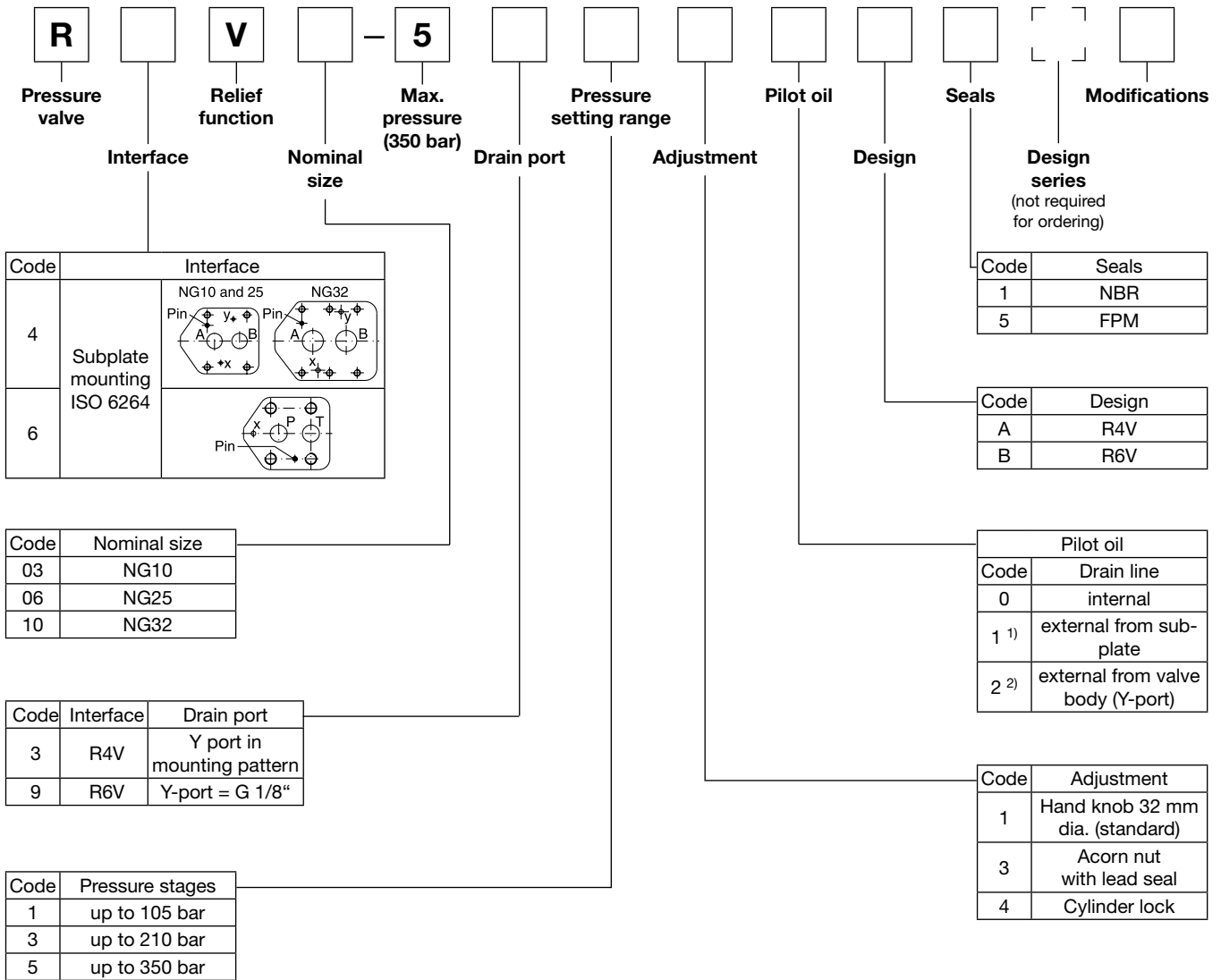

1) R4V only.
2) R6V only.

Ordering Code

R		V		- 5														
Pressure valve		Relief function		Max. pressure (350 bar)		Pressure setting range		Pilot oil		Solenoid voltage		Seals		Design series (not required for ordering)				
	Interface		Nominal size		Drain port		Adjustment		Vent valve function		Design							

Code		Interface	
4	Subplate mounting ISO 6264		
6			

Code		Nominal size
03		NG10
06		NG25
10		NG32

Code		Interface	Drain port
3		R4V	Y port in mounting pattern
9		R6V	Y-port = G 1/8"

Code		Pressure stages
1		up to 105 bar
3		up to 210 bar
5		up to 350 bar

Code		Adjustment
1		Hand knob (Standard)
3		Acorn nut with lead seal
4		Turning knob with key lock

Code		Modification
031 ¹⁾⁴⁾		Vent function with slow unloading
VFM ²⁾⁴⁾		Vent function with slow unloading

Code		Seals
1		NBR
5		FPM

Code		Design
A		R4V
B		R6V

Code		Voltage
G0R		12 V =
G0Q		24 V =
GAR ³⁾		98 V =
GAG ³⁾		205 V =
W30		110 V / 50 Hz 120 V / 60 Hz
W31		230 V / 50 Hz 240 V / 60 Hz

Code		Vent valve
09		Solenoid not activ. unpress. circulation
11		Solenoid activated unpress. circulation

Code		Pilot oil
		Drain line
0		internal
1 ¹⁾		external from subplate
2 ²⁾		external from valve body (Y-port)

4

1) R4V only.
 2) R6V only.
 3) To be used in combination with rectifier plugs at 120 VAC / 230 VAC power supply.
 4) Vent valve function code 09 only.

Technical Data

R4V/R6V

General			
Nominal size			NG10 NG25 NG32
Interface	Subplate mounting acc. ISO 6264 (DIN 24340)		
Mounting position	Unrestricted, horizontal mounting preferred		
Ambient temperature	[°C]	-20...+60	
MTTF _D value	[years]	75	
Weight	Series R4V	[kg]	2.7
	Series R6V	[kg]	4.5
Hydraulic			
Max. operating pressure	[bar]	Ports P (or A) and X up to 350, Port T (or B) and Y 30	
Pressure stages	[bar]	105, 210, 350	
Nominal flow	Series R4V	[l/min]	90
	Series R6V	[l/min]	250
Fluid			
Hydraulic oil according to DIN 51524			
Viscosity, permitted	[cSt] / [mm ² /s]	20 ... 400	
	recommended	[cSt] / [mm ² /s]	30 ... 80
Fluid temperature	[°C]	-20...+70 (NBR: -25...+70)	
Filtration		ISO 4406; 18/16/13	

4

R4V/R6V with vent function

General							
Nominal size			NG10 NG25 NG32				
Interface	Subplate mounting acc. ISO 6264 (DIN 24340)						
Mounting position	Unrestricted, horizontal mounting preferred						
Ambient temperature	[°C]	-20...+60					
MTTF _D value	[years]	75					
Weight	Series R4V	[kg]	4.4				
	Series R6V	[kg]	5.9				
Hydraulic							
Max. operating pressure	[bar]	Ports P (or A) and X up to 350, port T (or B) and Y 30					
Pressure stages	[bar]	105, 210, 350					
Nominal flow	Series R4V	[l/min]	90				
	Series R6V	[l/min]	250				
Fluid							
Hydraulic oil according to DIN 51524							
Viscosity, permitted	[cSt] / [mm ² /s]	20 ... 400					
	recommended	[cSt] / [mm ² /s]	30 ... 80				
Fluid temperature	[°C]	-20...+70 (NBR: -25...+70)					
Filtration		ISO 4406; 18/16/13					
Electrical							
Duty ratio	[%]	100 ED; CAUTION: coil temperature up to 150 °C possible					
Protection class		IP65 in accordance with EN 60529 (with correctly mounted plug-in connector)					
Code		G0R	G0Q	GAR	GAG	W30	W31
Supply voltage	[V]	12 V =	24 V =	98 V =	205 V =	110 V/50 Hz 120 V/60 Hz	230 V/50 Hz 240 V/60 Hz
Tolerance supply voltage	[%]	±10	±10	±10	±10	±5	±5
Current consumption	hold	[A]	2.72	1.29	0.33	0.13	0.6 / 0.55
	in rush	[A]	2.72	1.29	0.33	0.13	2.5 / 2.4
Power consumption	hold	[W]	32.7	31	31.9	28.2	70 / 70 VA
	in rush	[W]	32.7	31	31.9	28.2	280 / 290 VA
Solenoid connection		Connector as per EN175301-803, solenoid identification as per ISO 9461					
Wiring min.	[mm ²]	3 x 1.5 recommended					
Wiring length max.	[m]	50 recommended					

p/Q performance curves ¹⁾

NG10

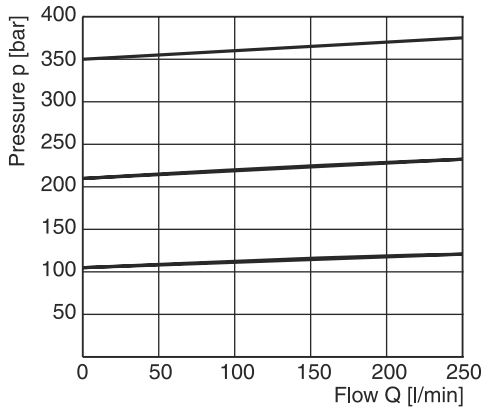

NG25

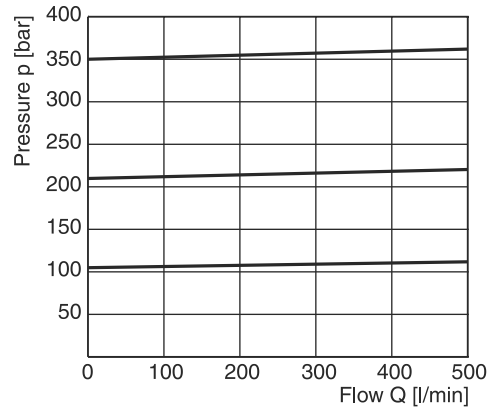

NG32

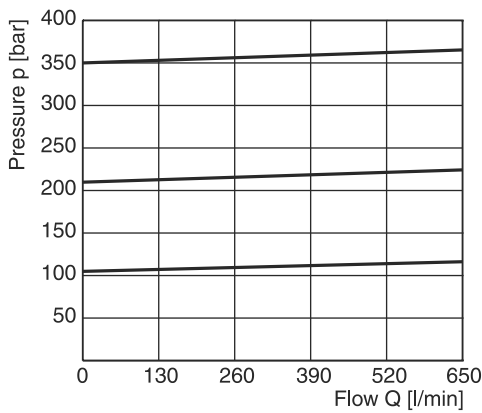

Minimum pressure curve

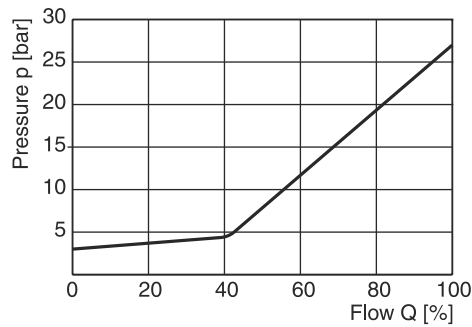

All characteristic curves measured with HLP46 at 50 °C.

¹⁾ The performance curves are measured with external drain.
 For internal drain the tank pressure has to be added to curve.

R6V

4

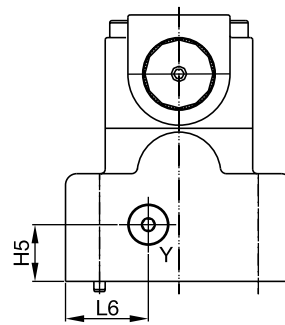
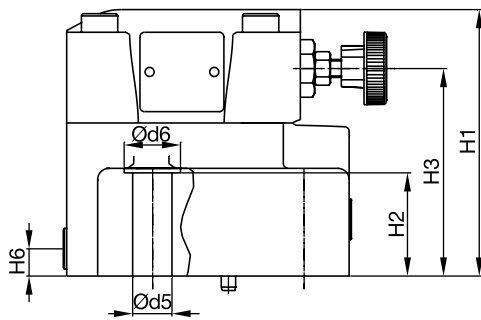
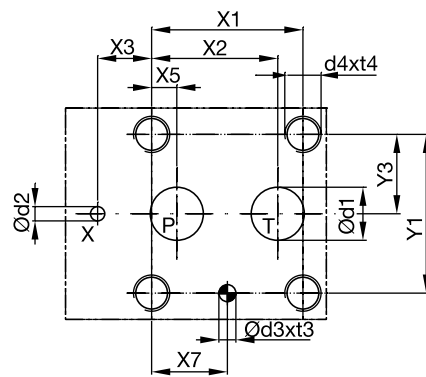
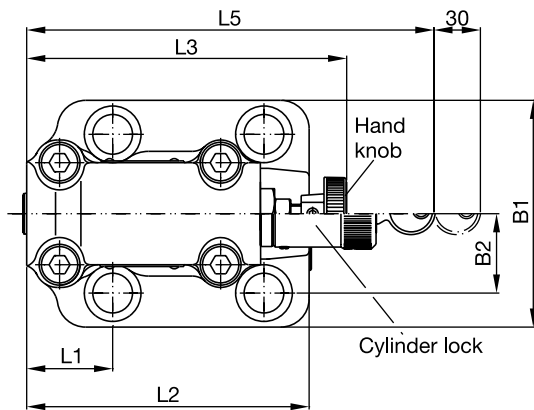

Y: external drain port G 1/8"

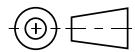

NG	ISO-code	x1	x2	x3	x4	x5	x6	x7	y1	y2	y3	y4	y5	y6
10	6264-06-09-*-97	53.8	47.5	0	-	22.1	-	22.1	53.8	-	26.9	-	-	-
25	6264-08-13-*-97	66.7	55.6	23.8	-	11.1	-	33.4	70	-	35	-	-	-
32	6264-10-17-*-97	88.9	76.2	31.8	-	12.7	-	44.5	82.6	-	41.3	-	-	-

Tolerance at X and Y pin holes and screw holes ± 0.1 , at port holes ± 0.2 .

NG	ISO-code	B1	B2	H1	H2	H3	H4	H5	H6	L1	L2	L3	L4	L5	L6
10	6264-06-09-*-97	80	26.9	114	27	88	-	20.5	25	52	117	141	-	180	29.5
25	6264-08-13-*-97	100	35	117.5	46.5	91.5	-	25	12	37.9	124.5	141	-	180	36.5
32	6264-10-17-*-97	120	41.3	124.5	51.3	98.5	-	26.5	13.5	44.3	153	141	-	180	46.5

NG	ISO-code	d1max	d2max	d3	t3	d4	t4	d5	d6	Subplate ¹⁾
10	6264-06-09-*-97	14.7	4.8	7.5	10	M12	20	13.5	20	SPP 3R6B 910
25	6264-08-13-*-97	23.4	6.3	7.5	10	M16	27	17.5	25	SPP 6R10B 910
32	6264-10-17-*-97	32	6.3	7.5	10	M18	28	20	30	SPP 10R12B 910

NG	Kit	Kit	Kit	Kit		Surface finish
				NBR	FPM	
10	BK494	4x M12x45 ISO 4762-12.9	108 Nm ± 15 %	S26-98589-0	S26-98589-5	
25	BK366	4x M16x70 ISO 4762-12.9	264 Nm ± 15 %	S26-96396-0	S26-96396-5	
32	BK507	4x M18x75 ISO 4762-12.9	398 Nm ± 15 %	S26-96392-0	S26-96392-5	

¹⁾ Details see chapter 12, series SPP.

R6V with vent function

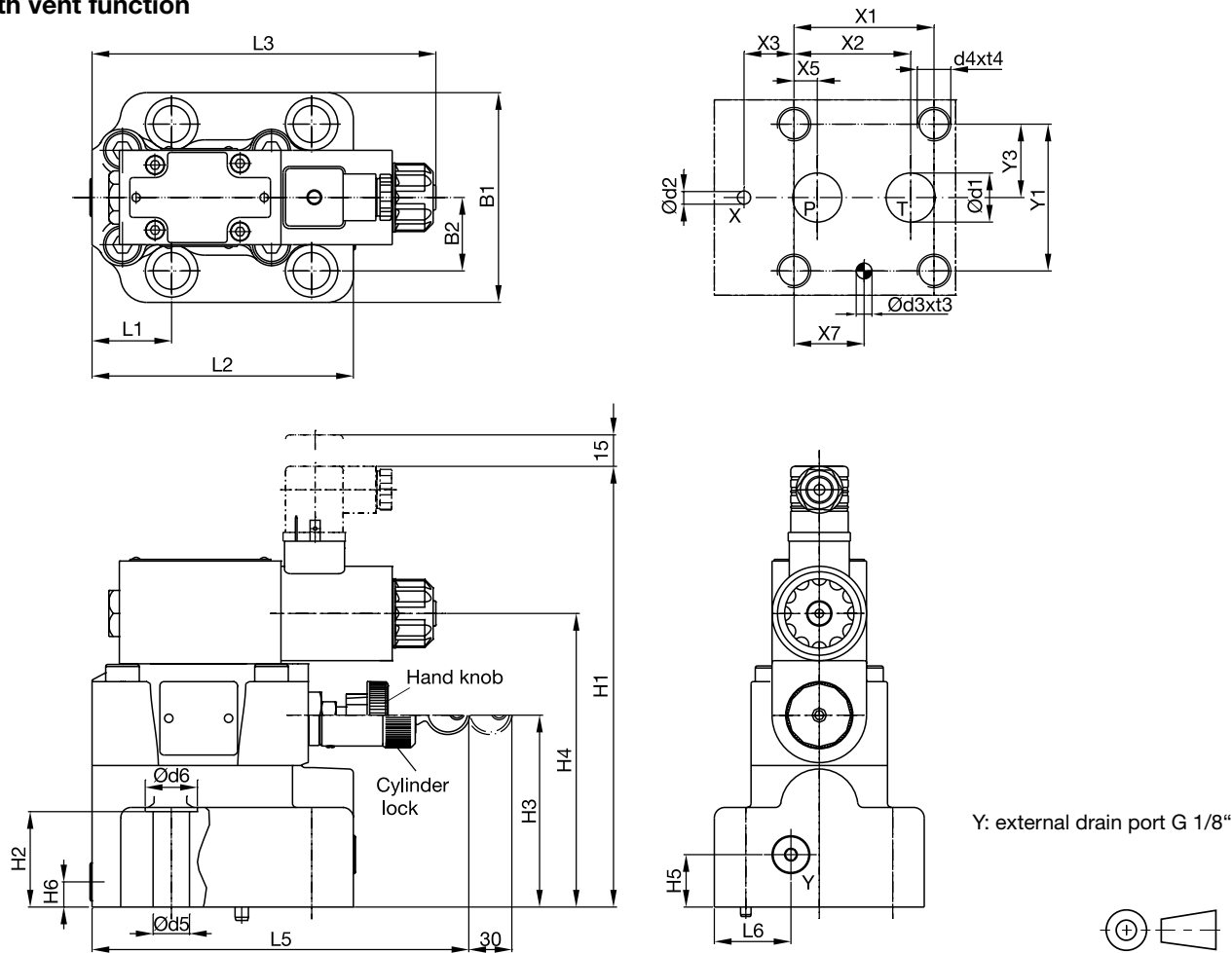

4

NG	ISO-code	x1	x2	x3	x4	x5	x6	x7	y1	y2	y3	y4	y5	y6
10	6264-06-09-*-97	53.8	47.5	0	-	22.1	-	22.1	53.8	-	26.9	-	-	-
25	6264-08-13-*-97	66.7	55.6	23.8	-	11.1	-	33.4	70	-	35	-	-	-
32	6264-10-17-*-97	88.9	76.2	31.8	-	12.7	-	44.5	82.6	-	41.3	-	-	-

Tolerance at X and Y pin holes and screw holes ±0.1, at port holes ±0.2.

NG	ISO-code	B1	B2	H1	H2	H3	H4	H5	H6	L1	L2	L3	L4	L5	L6
10	6264-06-09-*-97	80	26.9	203.4	27	88	136.3	25	12	52	117	163.8		180	36.5
25	6264-08-13-*-97	100	35	206.9	46.5	91.5	139.8	25	12	37.9	124.5	163.8	-	180	36.5
32	6264-10-17-*-97	120	41.3	213.9	51.3	98.5	146.8	25	12	44.3	153	163.8		180	36.5

NG	ISO-code	d1max	d2max	d3	t3	d4	t4	d5	d6	Subplate ¹⁾
10	6264-06-09-*-97	14.7	4.8	7.5	10	M12	20	13.5	20	SPP 3R6B 910
25	6264-08-13-*-97	23.4	6.3	7.5	10	M16	27	17.5	25	SPP 6R10B 910
32	6264-10-17-*-97	32	6.3	7.5	10	M18	28	20	30	SPP 10R12B 910

NG	Kit	Kit	Kit	Kit		Surface finish
				NBR	FPM	
10	BK494	4x M12x45 ISO 4762-12.9	108 Nm ±15 %	S26-98589-0	S26-98589-5	
25	BK366	4x M16x70 ISO 4762-12.9	264 Nm ±15 %	S26-96396-0	S26-96396-5	
32	BK507	4x M18x75 ISO 4762-12.9	398 Nm ±15 %	S26-96392-0	S26-96392-5	

¹⁾ Details see chapter 12, series SPP.

Dimensions

R4V

4

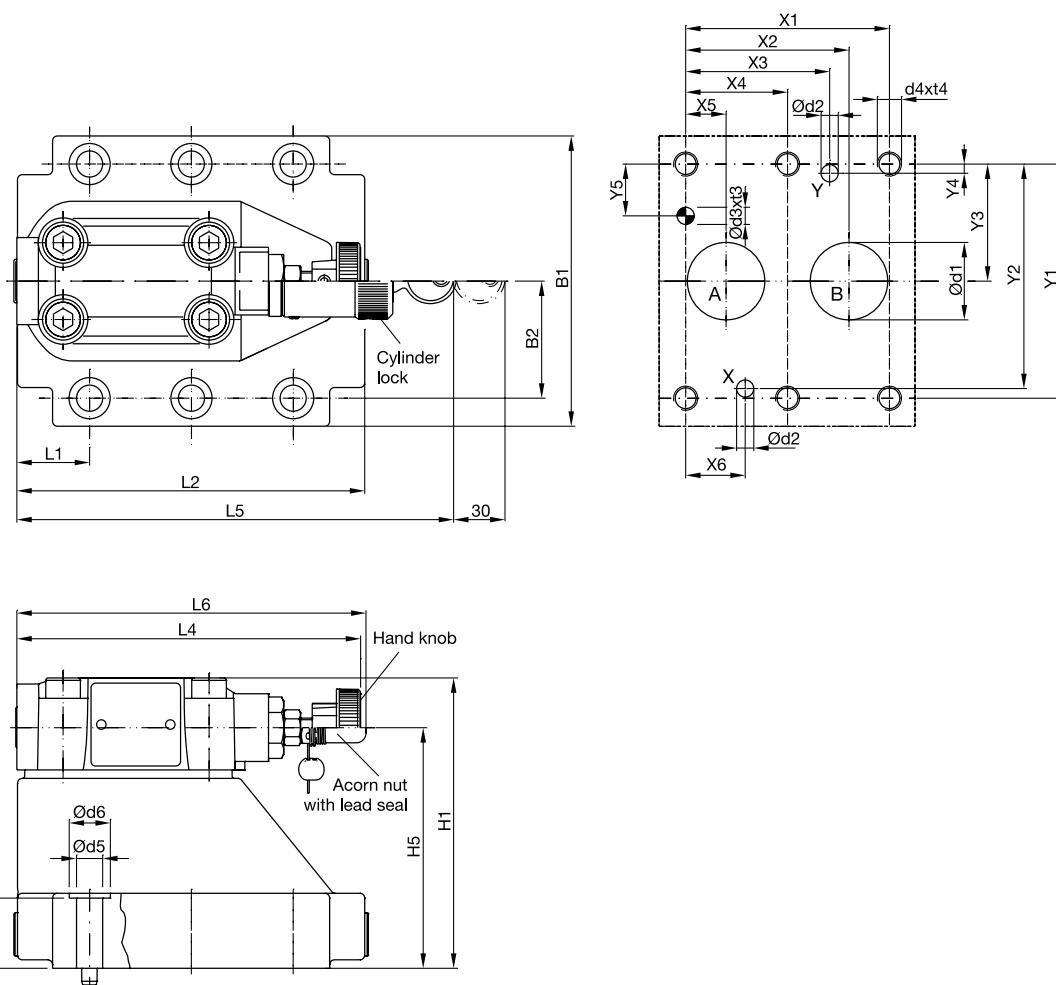

NG	ISO-code	x1	x2	x3	x4	x5	x6	x7	y1	y2	y3	y4	y5	y6
10	6264-06-07-* ⁻⁹⁷	42.9	35.8	21.5	-	7.2	21.5	0	66.7	58.8	33.4	7.9	14.3	-
25	6264-08-11-* ⁻⁹⁷	60.3	49.2	39.7	-	11.1	20.6	0	79.4	73	39.7	6.4	15.9	-
32	6264-10-15-* ⁻⁹⁷	84.2	67.5	59.5	42.1	16.7	24.6	0	96.8	92.8	48.4	3.8	21.4	-

Tolerance at X and Y pin holes and screw holes ±0.1, at port holes ±0.2.

NG	ISO-code	B1	B2	H1	H2	H3	H4	H5	H6	L1	L2	L3	L4	L5	L6
10	6264-06-07-* ⁻⁹⁷	87.3	33.35	83	21	-	-	62.5	-	25	90.8	-	143	181	144.8
25	6264-08-11-* ⁻⁹⁷	105	39.7	107.5	29	-	-	87	-	30.9	123	-	143	181	144.8
32	6264-10-15-* ⁻⁹⁷	120	48.4	120	30	-	-	99.5	-	29.8	143.5	-	143	181	144.8

NG	ISO-code	d1max	d2max	d3	t3	d4	t4	d5	d6	Subplate ¹⁾
10	6264-06-07-* ⁻⁹⁷	15	7	7.1	8	M10	16	10.8	17	SPP 3M6B 910
25	6264-08-11-* ⁻⁹⁷	23.4	7.1	7.1	8	M10	18	10.8	17	SPP 6M8B 910
32	6264-10-15-* ⁻⁹⁷	32	7.1	7.1	8	M10	20	10.8	17	SPP 10M12B 910

NG	Kit	Kit	Kit	Kit		Surface finish
				NBR	FPM	
10	BK505	4x M10x35 ISO 4762-12.9	63 Nm ±15 %	S26-58507-0	S26-58507-5	
25	BK485	4x M10x45 ISO 4762-12.9	63 Nm ±15 %	S26-58475-0	S26-58475-5	
32	BK506	6x M10x45 ISO 4762-12.9	63 Nm ±15 %	S26-58508-0	S26-58508-5	

¹⁾ Details see chapter 12, series SPP.

R4V with vent function

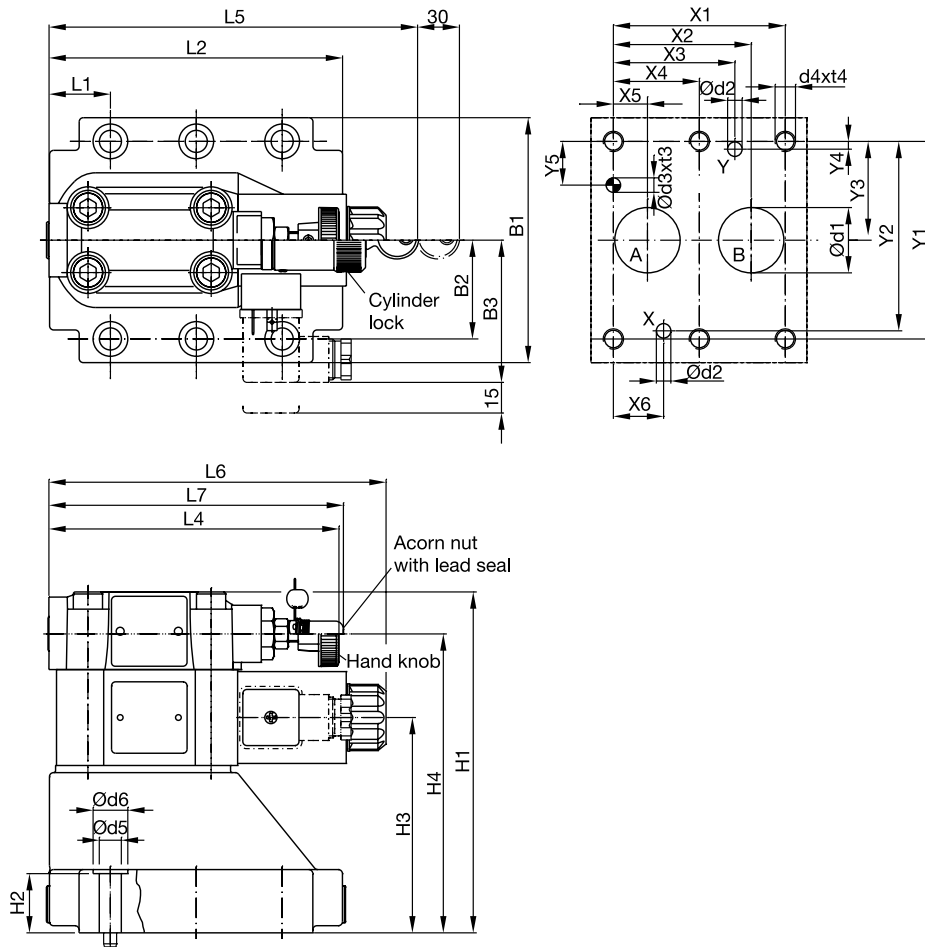

4

NG	ISO-code	x1	x2	x3	x4	x5	x6	x7	y1	y2	y3	y4	y5	y6
10	6264-06-07-*-97	42.9	35.8	21.5	-	7.2	21.5	0	66.7	58.8	33.4	7.9	14.3	-
25	6264-08-11-*-97	60.3	49.2	39.7	-	11.1	20.6	0	79.4	73	39.7	6.4	15.9	-
32	6264-10-15-*-97	84.2	67.5	59.5	42.1	16.7	24.6	0	96.8	92.8	48.4	3.8	21.4	-

Tolerance at X and Y pin holes and screw holes ±0.1, at port holes ±0.2.

NG	ISO-code	B1	B2	B3	H1	H2	H3	H4	H6	L1	L2	L3	L4	L5	L6	L7
10	6264-06-07-*-97	87.3	33.35	70	130	21	68.5	109.5	-	25	90.8	-	143	181	165.6	144.8
25	6264-08-11-*-97	105	39.7	70	154.5	29	93	134	-	30.9	123	-	143	181	165.6	144.8
32	6264-10-15-*-97	120	48.4	70	167	30	105.5	146.5	-	29.8	143.5	-	143	181	165.6	144.8

NG	ISO-code	d1max	d2max	d3	t3	d4	t4	d5	d6	Subplate ¹⁾
10	6264-06-07-*-97	15	7	7.1	8	M10	16	10.8	17	SPP 3M6B 910
25	6264-08-11-*-97	23.4	7.1	7.1	8	M10	18	10.8	17	SPP 6M8B 910
32	6264-10-15-*-97	32	7.1	7.1	8	M10	20	10.8	17	SPP 10M12B 910

NG	Kit	Kit	Kit	Kit		Surface finish
				NBR	FPM	
10	BK505	4x M10x35 ISO 4762-12.9	63 Nm ±15 %	S26-58507-0 ²⁾	S26-58507-5 ²⁾	
25	BK485	4x M10x45 ISO 4762-12.9	63 Nm ±15 %	S26-58475-0 ²⁾	S26-58475-5 ²⁾	
32	BK506	6x M10x45 ISO 4762-12.9	63 Nm ±15 %	S26-58508-0 ²⁾	S26-58508-5 ²⁾	
VV01, AC solenoid				S26-35237-0	S26-35237-5	
VV01, DC solenoid				S56-40609-0	S56-40609-5	

¹⁾ Details see chapter 12, series SPP.

²⁾ Please combine seal kit of one size with seal kit of VV01 solenoid for complete seal kit.