

The 3-way servo proportional valve with VCD® technology series TPQ are used in applications where high flow has to be precisely controlled at maximum dynamics. Typical applications are die casting, injection moulding and hydraulic presses.

**Function**

TPQ has a 2-stage design consisting of a DFplus pilot valve and a main stage with spool and LVDT.

With the DFplus pilot valve the TPQ achieves extremely fast response times: from 7 ms (NG25) up to 20 ms (NG80) with an accuracy of <0.1 % of the nominal flow. The pilot valve actively controls the spool – independent of the pressure conditions in the main ports.

It is basically required that the pilot pressure is at the level of the system pressure. At low system pressure the pilot pressure should be min. 140 bar, when high valve dynamics are desired.

The integrated electronics in the pilot of the TPQ has two control loops for the main cone and the pilot spool.

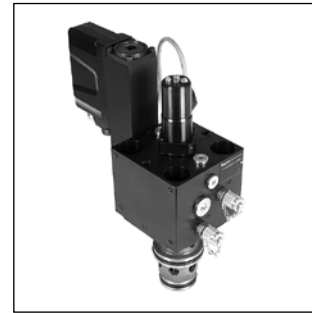

TPQ 040

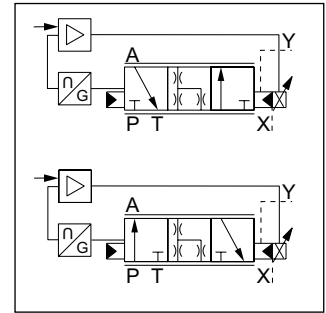

**Features**

- Active pilot operated 3-way servo proportional valve
- Cavity according to Parker house norm
- Fast step response
- Flow direction A to T and P to A
- Completely mounted adapted unit with integrated electronics
- In order to ensure the basic position, pilot pressure is required
- 6 sizes NG25 up to NG80

**TPQ 040 P**

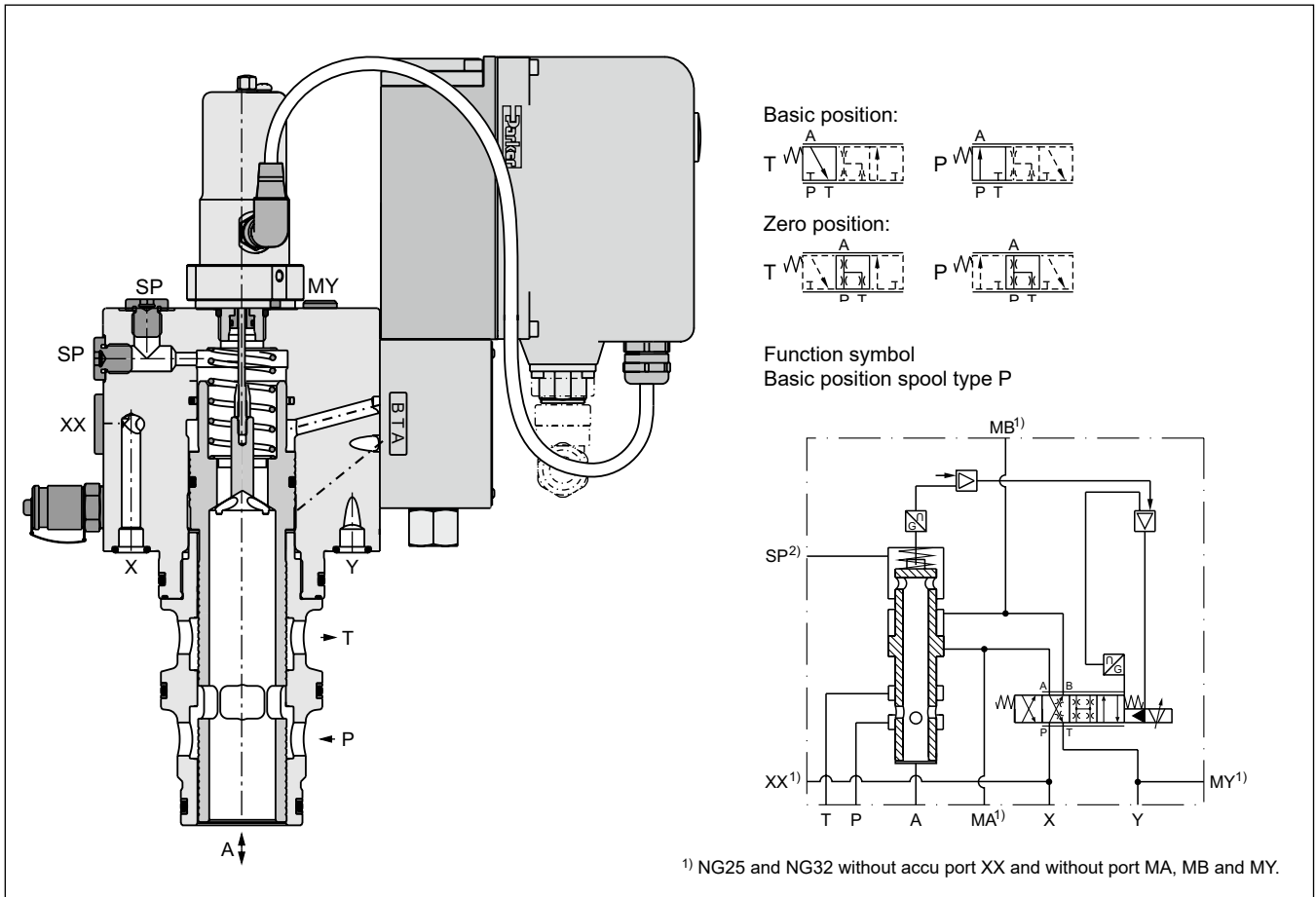

<sup>1)</sup> NG25 and NG32 without accu port XX and without port MA, MB and MY.

Ordering Code / Performance Curves

Ordering code

<b>TPQ</b>		<b>W</b>	<b>H</b>	<b>2</b>	<b>5</b>		<b>2</b>			<b>0</b>	
3-way servo proportional valve with LVDT	Nominal size	Parker Slip-in cartridge	Closed loop, VCD® performance, integrated electronics	Linear spool	Nominal flow	Spool type	Pilot oil supply external, drain external	Seal	Input signal	Standard electronics	Design series (not required for ordering)

Code	Nominal size
025	NG25
032	NG32
040	NG40
050	NG50
063	NG63
080	NG80

Code	Signal range
B	0...±10 V
E	0...±20 mA
S	4...+20 mA

Code	Seal
N	NBR
V	FPM
H	for HFC fluid

  

Zerolap		
Code	Spool type Input signal - 0 +	Basic position
P		P → A
T		A → T

The DFplus pilot valve is also available with EtherCAT interface, see chapter 3, D\*FP and D\*1FP with EtherCAT.

Please order connector separately  
Angle female connector must be used for NG25 to NG50.

Characteristic flow/signal line

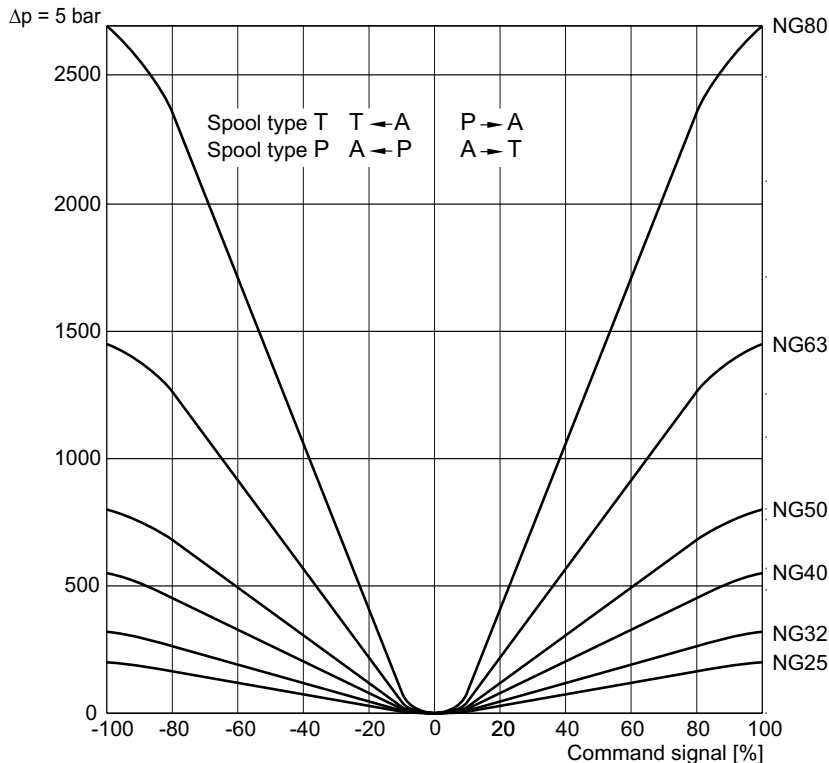

$$Q_{\text{actual}} = Q_{\text{nominal}} \cdot \sqrt{\Delta p_{\text{actual}} / \Delta p_{\text{nominal}}}$$

Characteristic curve measured with HLP46 at 50 °C.

<b>General</b>						
Design	Proportional throttle valve, slip-in cartridge					
Nominal size	DIN	<b>NG25</b>	<b>NG32</b>	<b>NG40</b>	<b>NG50</b>	<b>NG63</b> <b>NG80</b>
Mounting position	unrestricted					
Ambient temperature	[°C]	-20...+50				
Weight	[kg]	11	13	15	26	52   105
Vibration resistance	[g]	10 sinus 5...2000 Hz acc. IEC 68-2-6 10 (RMS) random noise 20...2000 Hz acc. IEC 68-2-36 15 shock acc. IEC 68-2-27				
<b>Hydraulic</b>						
Max. operating pressure	[bar]	Ports A, P, T, X up to 350, XX observe accumulator pressure rating; port Y: max. 35				
Fluid	Hydraulic oil according to DIN 51524					
Fluid temperature	[°C]	-20...+60 (NBR: -25...+60)				
Viscosity recommended	[cSt]/[mm²/s]	30...80				
Viscosity permitted	[cSt]/[mm²/s]	20...400				
Filtration	ISO 4406; 18/16/13					
Nominal flow at Δp = 5 bar	[l/min]	200	320	550	800	1450   2700
Recommended max. flow	[l/min]	500	1000	1600	2250	3500   6500
Nominal overlap	[%]	< 1.5				
Flow direction	A to T or P to A					
Pilot pressure	[bar]	must be as high as system pressure				
Pilot oil supply	external via X					
Pilot oil drain	external via Y					
Leakage in pilot valve at 100 bar	[ml/min]	< 400				
Leakage in main stage at 100 bar	[l/min]	NG32 to 63 < 2.5; NG80 < 4.0				
Pilot valve size	<b>NG06</b>			<b>NG10</b>		
Max. pilot flow at 140 bar pilot press.	[l/min]	25	25	25	25	50   60
<b>Static/dynamic</b>						
Step response at pilot press. >140 bar	[ms]	7	11	11	18	19   20
Frequency response at pilot press. >140 bar	Amplitude -3 dB; ±5 %					
	[Hz]	210	105	70	45	35   30
	[Hz]	170	125	110	95	75   70
Phase -90°; ±5 %						
Hysteresis	[%]	< 0.1				
Sensitivity	[%]	< 0.05				
Temperature drift of center position	[%/K]	< 0.025				
<b>Electrical</b>						
Duty ratio	[%]	100				
Protection class	IP65 in accordance with EN 60529 (with correctly mounted plug-in connector)					
Supply voltage / ripple	[V]	DC 22 ... 30, electric shut-off at < 19, ripple < 5 % eff., surge free				
Current consumption max.	[A]	3.5				
Pre-fusing	[A]	4.0 A medium lag				
Input signal Code B	Voltage	+10...0...-10, ripple < 0.01 % eff., surge free				
	Impedance	100				
Code E	Current	+20...0...-20, ripple < 0.01 % eff., surge free				
	Impedance	< 250				
Code S	Current	4...12...20, ripple < 0.01 % eff., surge free				
	Impedance	< 250				
Differential input max.	[V]	30 for terminal D and E against PE (terminal G), 11 for terminal D and E against 0V (terminal B)				
Enable signal	[V]	5...30, Ri = > 8 kOhm				
Diagnostic signal	[V]	+10...0...-10 / +12.5 error detection, rated max. 5 mA				
EMC	EN 61000-6-2, EN 61000-6-4					
Electrical connection	6 + PE acc. EN 175201-804					
Wiring min.	[mm²]	7x1.0 (AWG16) overall braid shield				
Wiring length	[m]	50				

**Installation Recommendations / Electronics**

**Installation recommendation**

An insufficient pilot oil supply (e.g. due to long distances and/or small diameters) can negatively influence the dynamics of the TPQ valve.

To avoid this, an accumulator can be connected to port XX at the valve body of the TPQ. A short-term undersupply with pilot oil can be compensated via this accumulator.

Sizing data: see operation manual.

Please also consider the Parker accumulator product range and the Parker Accumulator Sizing Software.

**Block circuit diagram electronics**

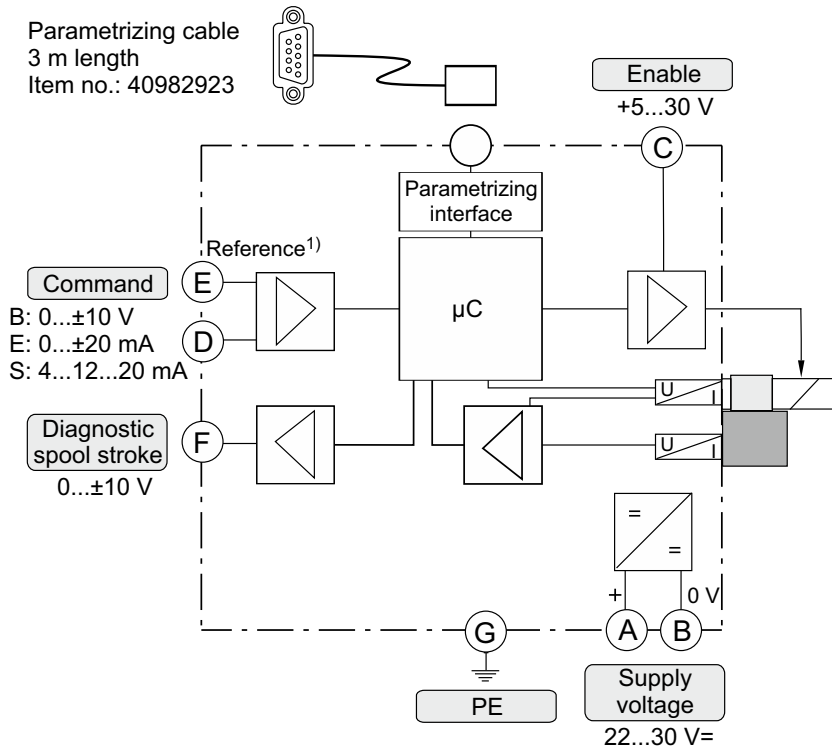

**Connection diagrams electronics**

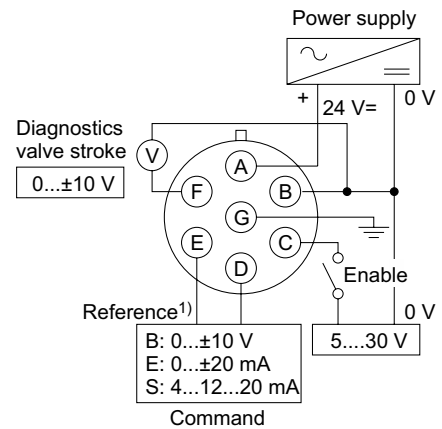

8

**Female connector for NG63 to NG80**  
 (EMC conform)

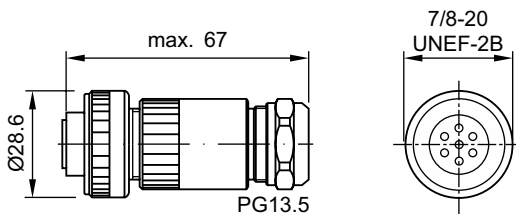

ID no. 5004072

**Angle female connector for NG25 to NG50**  
 (EMC conform)

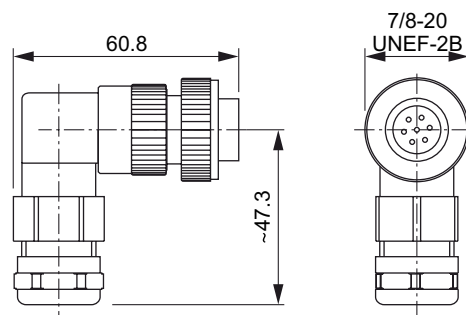

ID no. 5005160

Please order plugs separately.

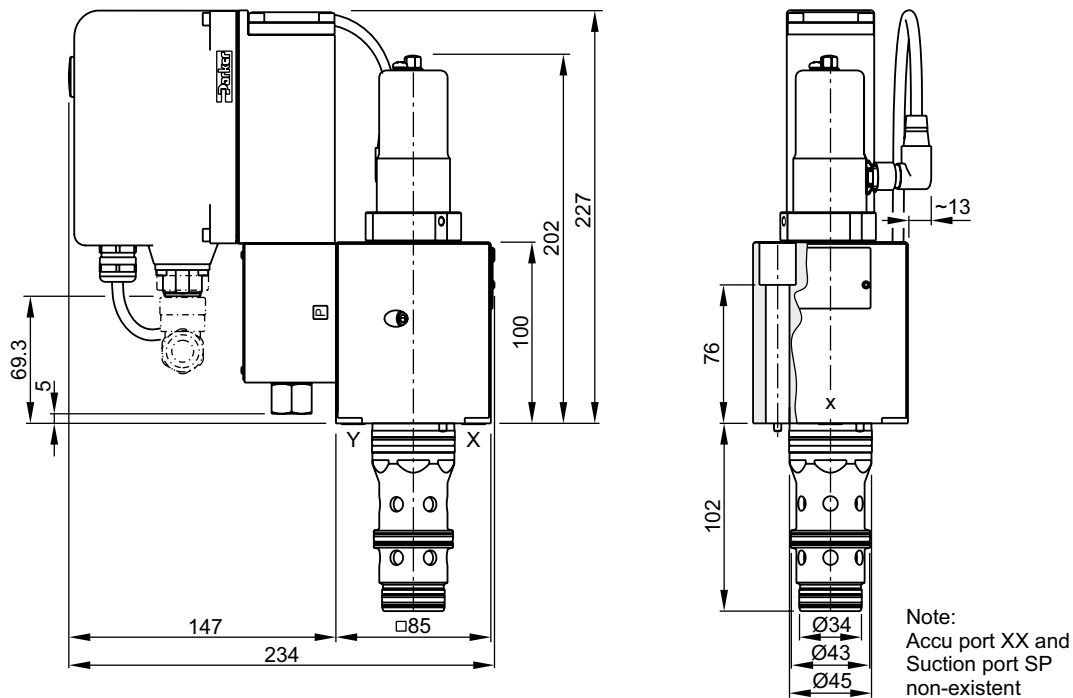

<sup>1)</sup> Do not connect with the supply voltage zero.

**NG25**

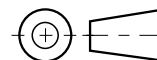
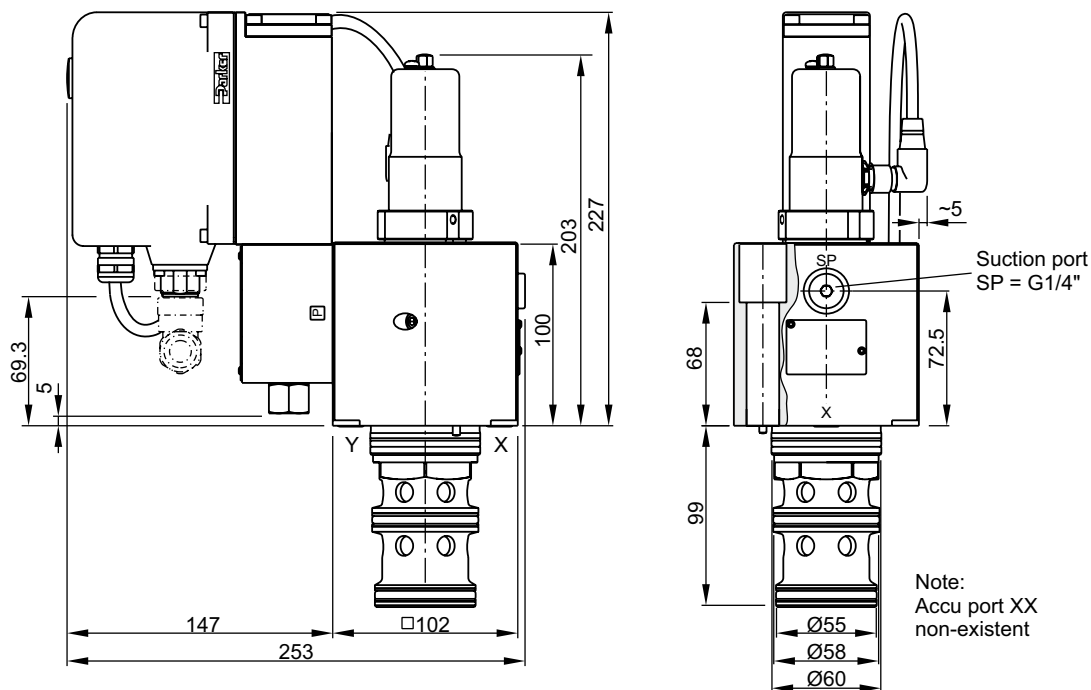

**NG32**



NG	Bolt kit - 		NBR	 Kit	FPM
25	BK504 4x M12x100 ISO 4762-12.9	108 Nm	SK-TPQ025EN30		SK-TPQ025EV30
32	BK529 4x M16x100 ISO 4762-12.9	264 Nm	SK-TPQ032EN30		SK-TPQ032EV30

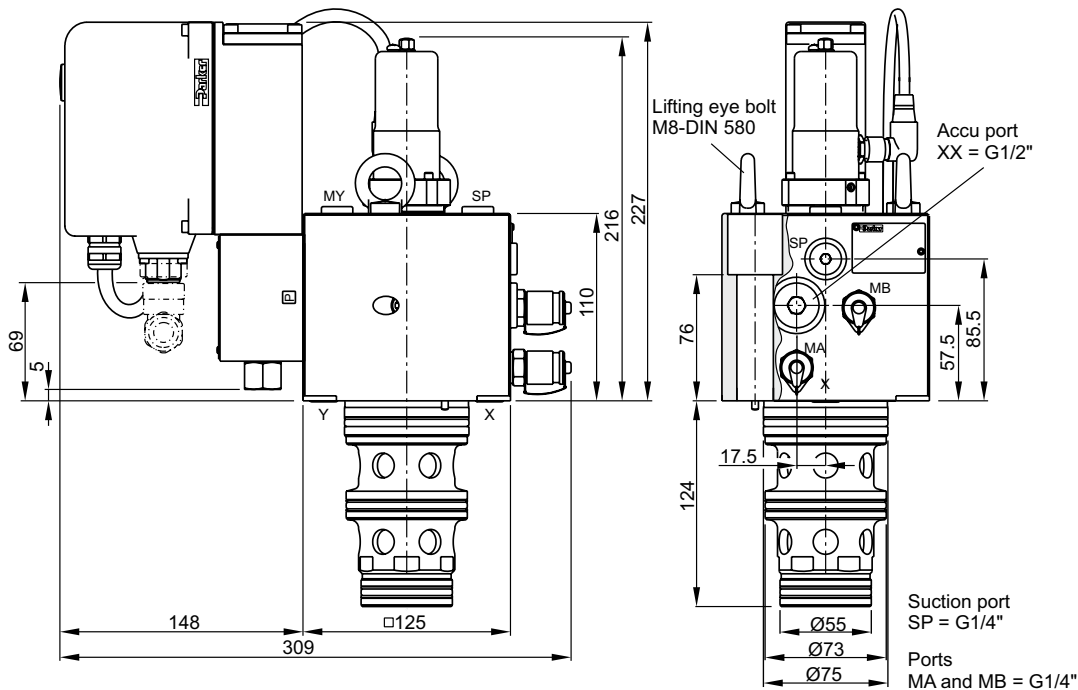

**NG40**

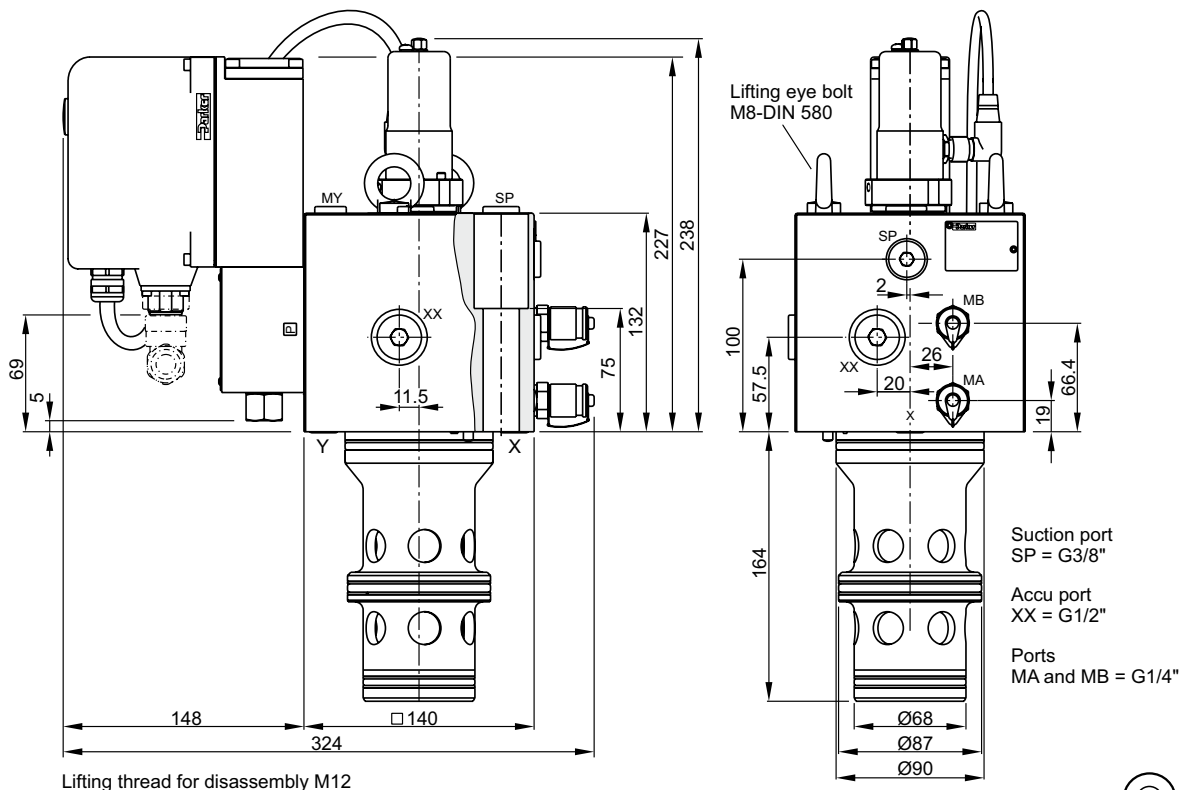

**NG50**



8

NG	Bolt kit - 		NBR	Kit 	FPM
40	BK481 4 x M20x110 ISO 4762-12.9	517 Nm	SK-TPQ040EN30		SK-TPQ040EV30
50	BK481 4 x M20x110 ISO 4762-12.9	517 Nm	SK-TPQ050EN30		SK-TPQ050EV30

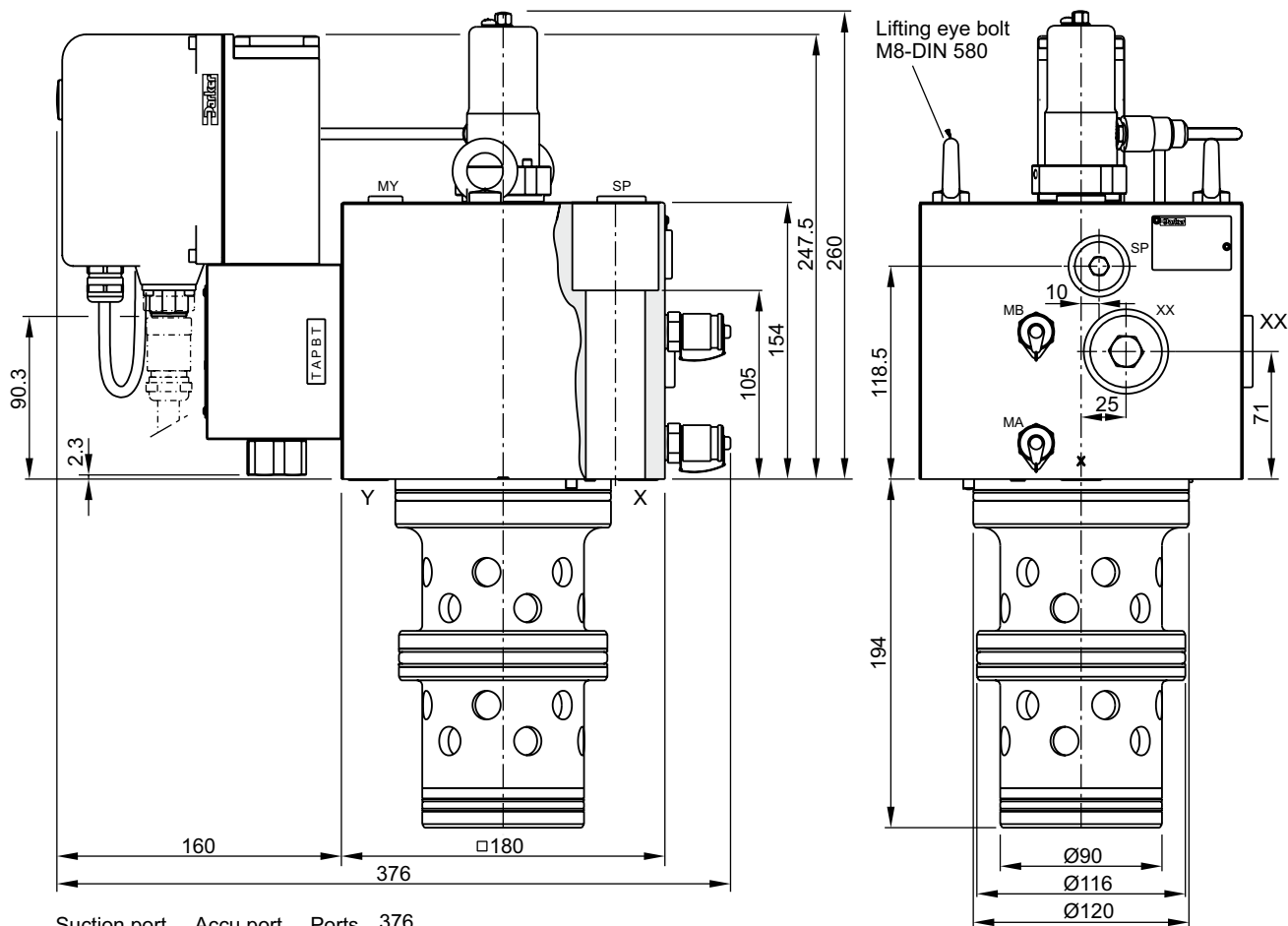

**NG63**

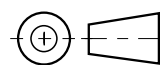

Suction port Accu port Ports 376  
 SP = G1/2" XX = G3/4" MA and MB = G1/4"

Lifting thread for disassembly M12



NG	Bolt kit - 		NBR	 Kit	FPM
63	BK518 4x M30x160 ISO 4762-12.9	1775 Nm	SK-TPQ063EN30		SK-TPQ063EV30

**NG80**

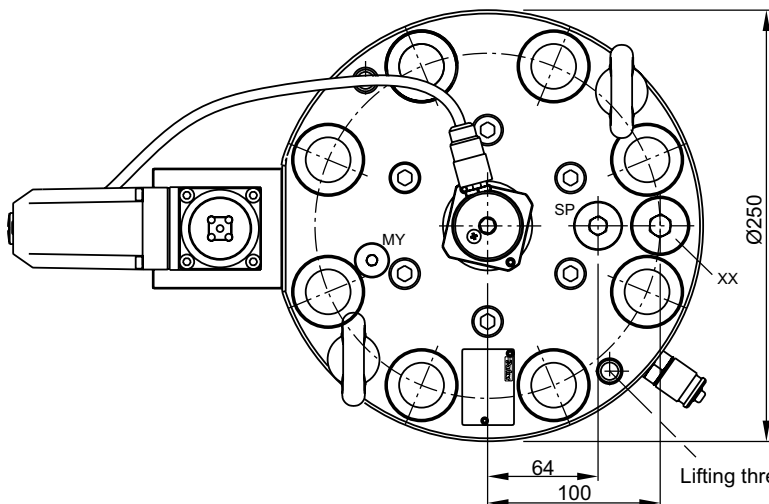

Accu port  
 XX = G3/4"

Suction port  
 SP = G1/2"



Ports  
 MA and MB = G1/4"

Lifting thread for disassembly M12

Lifting eye bolt  
 M12-DIN 580

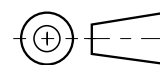
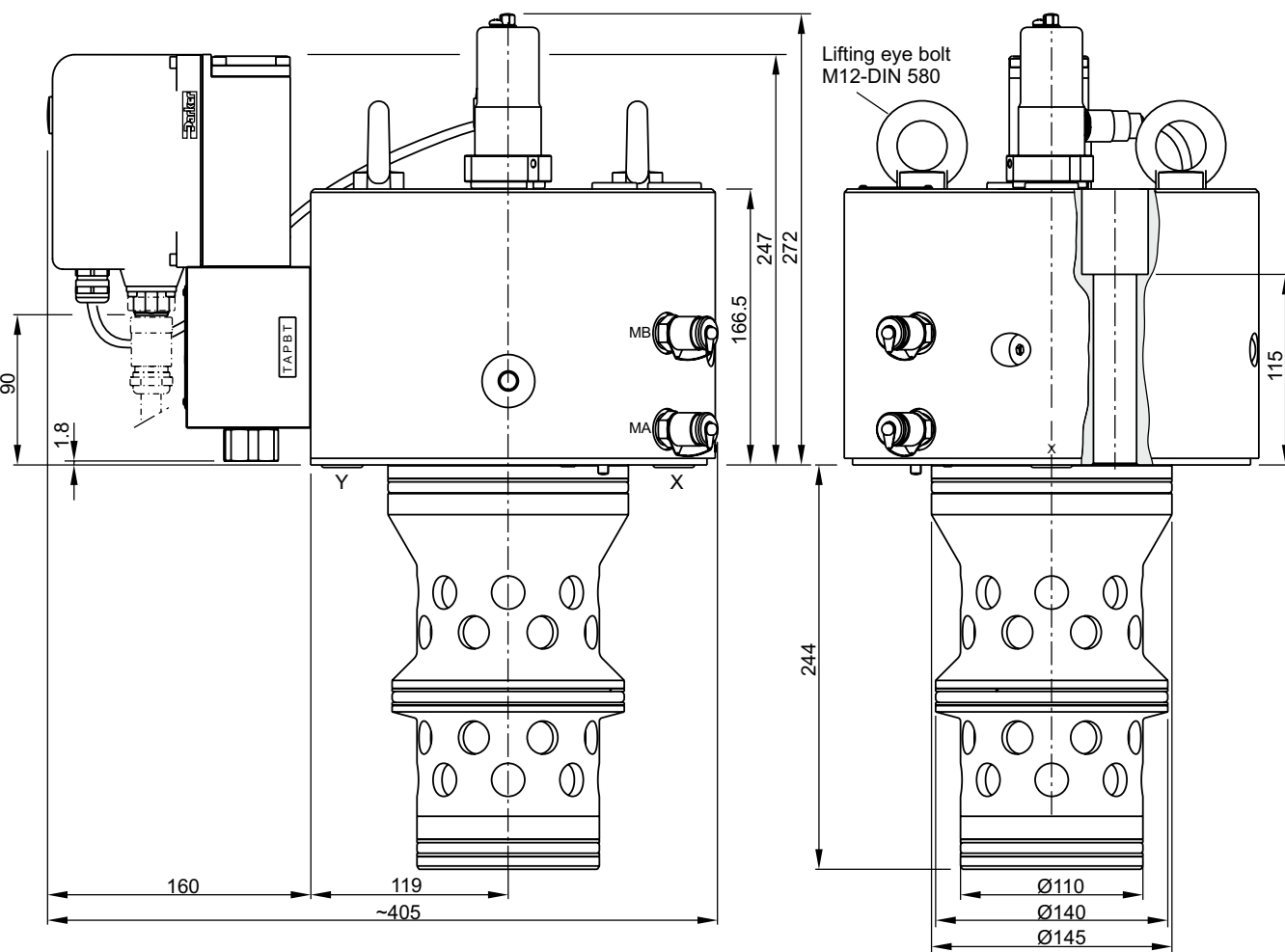
8



NG	Bolt kit - 		NBR	Kit 	FPM
80	BK530 8x M24x160 ISO 4762-12.9	890 Nm	SK-TPQ080EN30		SK-TPQ080EV30



**NG32 to NG63**

**NG80**

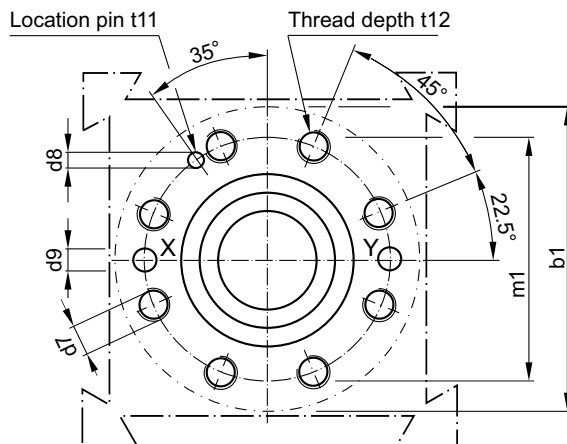
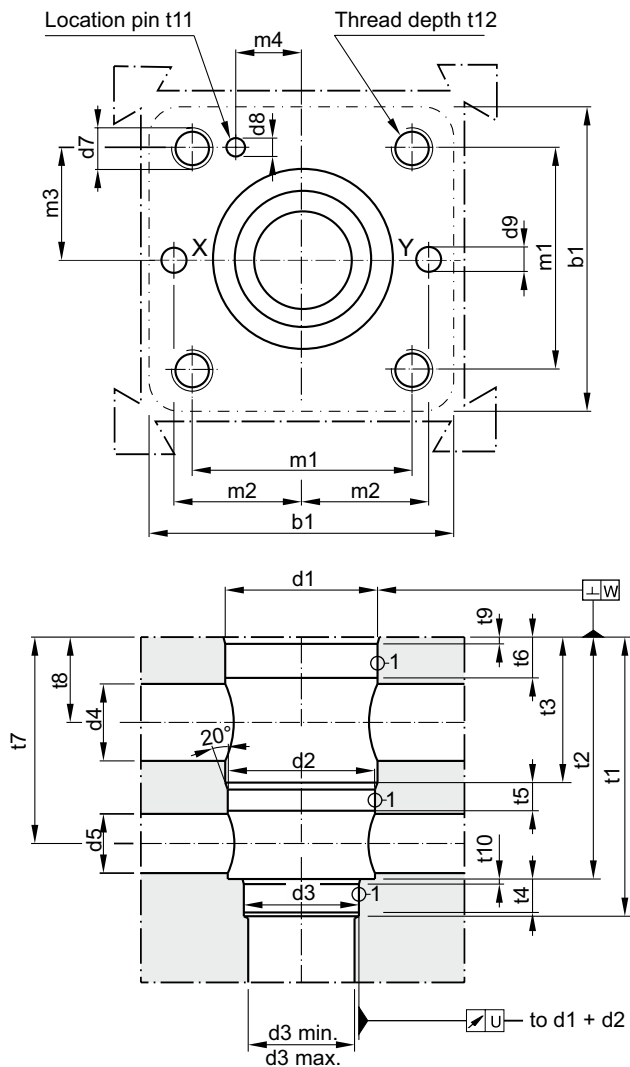

Required surface finish:

$$\sqrt{R_{\max} 25}, \textcircled{1} = \sqrt{R_{\max} 8}$$

**8**

Size	b1	d1 H7	d2 H7	d3 H7	d3 min.	d3 max.	d4 max.	d5 max.	d7	d8 H13	d9	U	W
25	85	45	43	34	17	25	25	21	M 12	4	7.5	0.03	0.05
32	102	60	58	55	32	54	28	28	M 16	6	8	0.03	0.1
40	125	75	73	55	40	54	38	32	M 20	6	10	0.05	0.1
50	140	90	87	68	50	67	63	38	M 20	8	10	0.05	0.1
63	180	120	116	90	63	89	64	52	M 30	8	12	0.05	0.2
80	250	145	140	110	80	109	70	66	M 24	10	16	0.05	0.2

Size	m1 ±0.2	m2 ±0.2	m3 ±0.2	m4 ±0.2	t1 <sup>+3</sup> / <sub>+1</sub>	t2 ±0.2	t3 ±0.2	t4	t5	t6	t7 ±0.2	t8 ±0.2	t9	t10	t11	t12
25	58	33	29	16	103	89 <sup>+0.3</sup>	56	11.5	15	17	78	43.5	2.5x15°	2.5x15°	10	35
32	70	41	35	17	100	85	43	13.5	16	18	71	28.5	2.5x15°	2.5x15°	10	35
40	85	50	42.5	23	125	105	54	15	18	21	88	34	3x15°	3x15°	10	45
50	100	58	50	30	165	143	84.5	18	18	21	122	51.5	4x15°	3x15°	10	45
63	125	75	62.5	38	195	165	83.5	25	29.5	33	138.5	50	4x15°	4x15°	10	65
80	200	-	-	-	245	215	123	25	27	60	181	87	5x15°	5x15°	10	50